

VST Installation Procedure for Stage II Vacuum Assist Nozzles

Part Number Series: VST-VR-NA(cc), VST-VR-NA(ccR)

cc = Scuff Guard Color Code and R = rebuilt



Vapor Systems Technologies, Inc.

650 Pleasant Valley Drive
Springboro, Ohio 45066 (USA)

Toll Free: 1-888-878-4673

Phone: 937-704-9333

Fax: 937-704-9443

www.vsthose.com

INSTALLATION PREPARATION

This procedure must be followed to insure leak-proof installation and operation of these nozzles.

1. Turn off and tag the power to the dispenser. Dispenser must be de-energized prior to service to avoid personal injury.
2. Barricade work area to block vehicle access to the dispenser.
3. Close dispenser shear valve prior to removing hanging hardware (hoses, safety breakaways, and nozzles).
4. Drain liquid product from the hanging hardware set into an approved container prior to replacing any hanging hardware component.
5. Remove hanging hardware from the dispenser prior to making replacement component assembly connections. VST recommends connecting the whip hose to dispenser as the last connection during hanging hardware assembly.

INSTALLATION

1. **STOP!** If this is a new facility installation, the fueling point must be flushed into an approved container before installing the nozzle. Using this nozzle to flush the system could result in foreign material becoming lodged in the nozzle's valve and cause it not to shut off.
2. Initial inspection:
 - a. Carefully unpack nozzle from shipping carton
 - b. Inspect nozzle exterior for any damage.
 - c. Inspect threads, lever, hold-open clip, spout, collection sleeve, band clamps, and face seal to determine that they are present and undamaged.
 - d. Inspect spout vent hole. It should be clear of debris.
3. Lightly lubricate **ALL** O-Rings on mating connections with petroleum jelly or other suitable lubricant. **DO NOT USE** pipe dope or thread sealant.
4. Attach nozzle onto mating hose connection and tighten by hand.
5. Tighten the nozzle connection to 50 foot-pounds of torque. **DO NOT OVER TIGHTEN.** Use a torque wrench with an open-end attachment to fit the hose couplings and an open-end wrench to properly tighten coupling connections. **DO NOT USE** channel-locks or pliers to tighten hose joints. Proper ft./lb. torque may not be achieved with these tools.

Figure 1.

Hanging Hardware Assembly

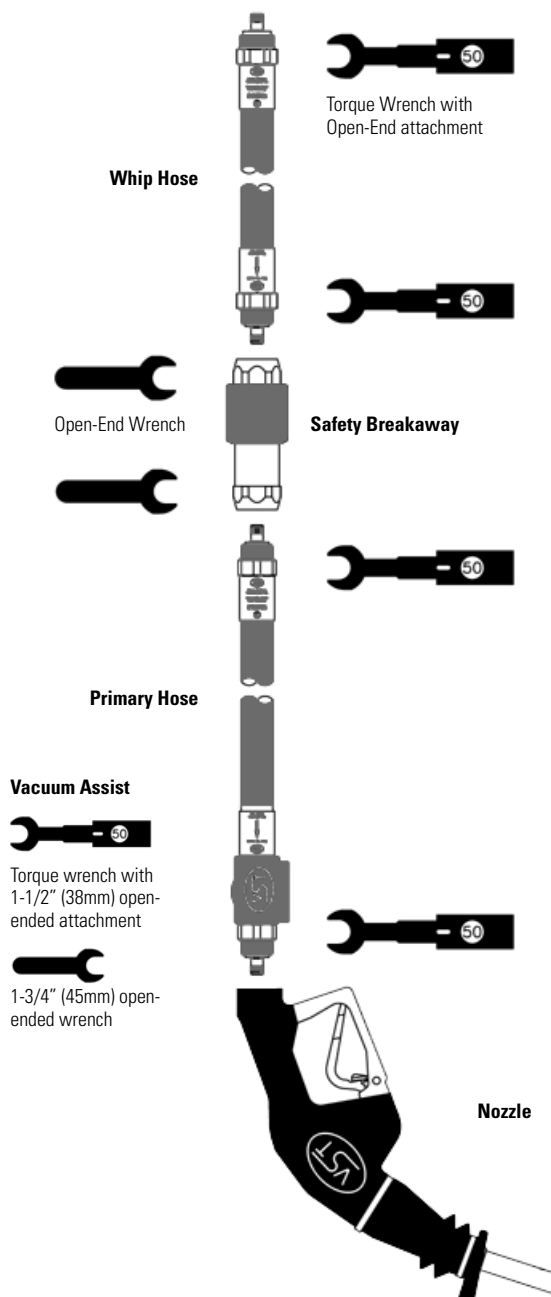

VST Installation Procedure for Stage II Vacuum Assist Nozzles

Part Number Series: VST-VR-NA(cc), VST-VR-NA(ccR)

cc = Scuff Guard Color Code and R = rebuilt

- Purge air from the system by pumping one-tenth (1/10) to two-tenths (2/10) of a gallon of fuel into an approved container. Inspect nozzle connection for liquid leaks and make proper adjustments at hose connection if necessary.
- Check the nozzle shut-off action by dispensing fuel into an approved container at least three times to assure proper automatic operation. To test, operate the nozzle and submerge the spout tip in fuel until the fuel level covers the vent hole. The main valve of the nozzle automatically shuts off when liquid covers the vent hole at the end of the spout. The nozzle is not designed to operate on gravity flow. The dispenser should deliver a minimum of 3 gpm. Hold open latch will disengage automatically when liquid covers the vent hole in the spout.
- Measure the resistance between the dispenser outlet casting and the tip of the nozzle spout. Use an electronic multimeter set on the high range of the ohmmeter function. Resistance should not indicate more than 70,000 ohms per foot of hose. Example: The measured resistance for a 12-foot hose must not exceed 840,000 ohms (840 kilohms).

DISABLING THE GILBARCO VAPORVAC® "PUFF CIRCUIT"

IMPORTANT: The Gilbarco VaporVac system uses a boost or "puff" circuit that temporarily increases the speed of the vapor pump/motor during the beginning of the vehicle refueling transaction. The "puff" circuit must be disabled when using the VST ENVIRO-LOC™ ORVR Solution hanging hardware. If the

"puff" circuit is not disabled, the ORVR relief valve could block the vapor path while fueling a non-ORVR equipped vehicle. The following steps should be followed to disable the "puff" circuit:

- Make sure that the nozzle hooks/flaps are in the "OFF" position and disconnect all power to the dispenser.
- Open the electronic cabinet door and locate the VaporVac control electronics. The VaporVac control electronics are located:
 - Encore™ series dispensers — In the upper left corner of the electronic cabinet.
 - Advantage® series dispensers (factory installed VaporVac) — In the center of the upper card cage of the electronic cabinet.
 - Advantage® and MPD series dispensers (retrofit kits) — In the upper housing/canopy of the dispenser.
- Locate the T19401-G2 or T18021-G1 VaporVac controller printed circuit board assembly. The VaporVac controller PDA has six (6) red LED's and two (2) blue potentiometers on the very front of the board that can be used as a good visual indicator. (see Figure 2)
- Locate the jump jack behind connector P1102 (see Figure 2). You will also see "CAL" and "OP" on each end of the jump jack positions.
- Remove the jump jacks from positions JP1 and JP2. Removing these two (2) jump jacks will disable the puff circuit.

6. Close and properly secure the electronic cabinet door. Restore power to the dispenser.

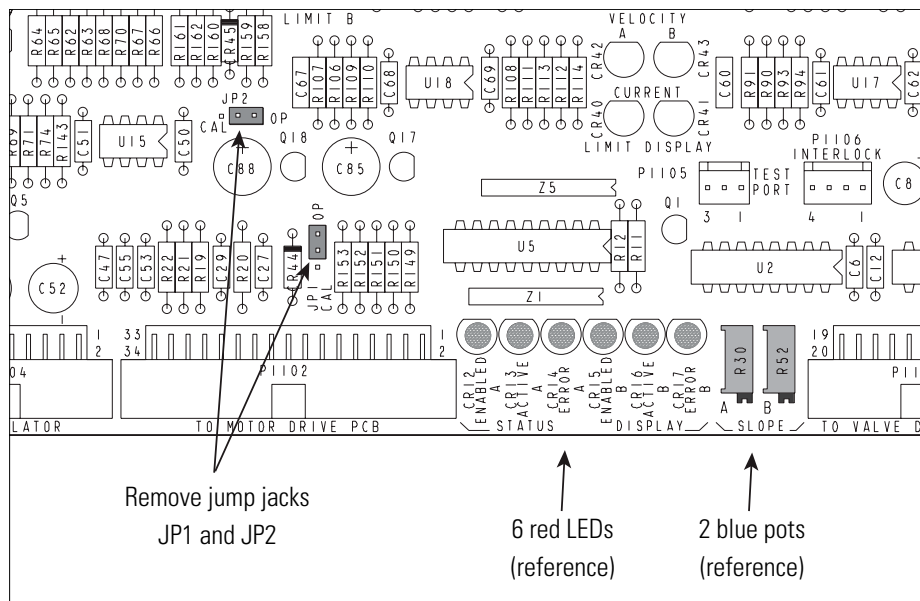

Figure 2.
Locating "Puff"
Circuit Jump Jack

VST Installation Procedure for Stage II Vacuum Assist Nozzles

Part Number Series: VST-VR-NA(cc), VST-VR-NA(ccR)

cc = Scuff Guard Color Code and R = rebuilt

A/L (Air-to-Liquid) TESTING

1. Vent the UST vapor system to atmosphere before starting the A/L Testing procedure.
2. Securely attach a CARB approved vapor flow meter (or similar device) to the hose-barb fitting on the A/L Test Adapter.
3. Slide the A/L Test Adapter over the nozzle spout so that the side of the hose-barb fitting is closest to the nozzle body so that the adapter face mates firmly and seals against the face seal. (see Figure 3.)
4. Compress the vapor collection sleeve bellows with the A/L Test Adapter and tighten the knob on the A/L Test Adapter so that it is securely attached to the spout.
5. Initialize the Flow Meter to begin to measure the volume of vapor collected.
6. The dispenser must be turned on and authorized to be able to open the nozzle and dispense fuel.

WARNING! Static electric spark could ignite fuel causing a fire. Place approved container on the ground prior to and during test. Nozzle must be in contact with the container until the testing is complete to discharge any static electricity generated during the test.

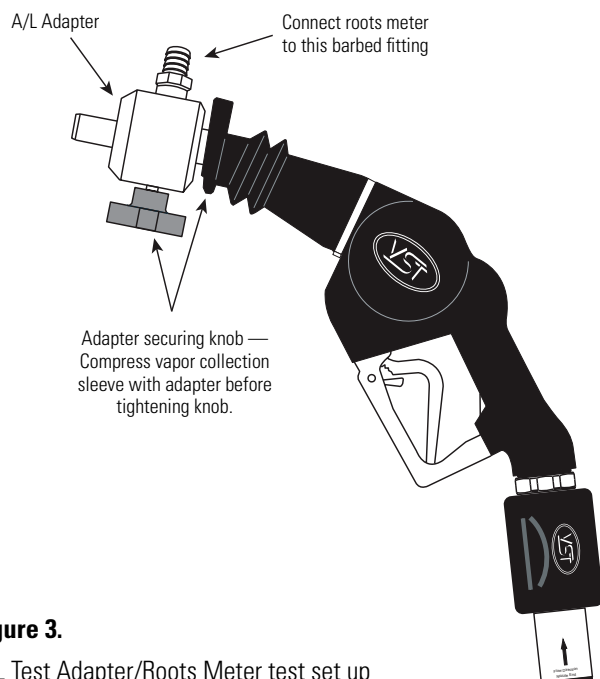

Figure 3.
A/L Test Adapter/Roots Meter test set up

7. Flow approximately 5 gallons of fuel into an approved test container with the nozzle lever held in the full open position.
8. Calculate the A/L ratio by dividing the volume of vapor collected by the volume of fuel dispensed.
9. If the A/L ratio is between 0.9 to 1.0, then no further adjustments are necessary.
10. If the A/L ratio is outside of the 0.9 to 1.0 range, then follow the vacuum system manufacturer's instructions for adjusting vapor flow rates. Retest and verify that adjustments now bring the A/L ratio into compliance.
11. Reseal the UST vapor system after the A/L ratios are set for all fueling points.

NOTE: A/L ratios for the VST ENVIRO-LOC ORVR Solution system must intentionally be set to the lower half of the CARB approved A/L range due to the "A/L boost" that is created by the increased vacuum generated in the UST by the ORVR valve.

CHECKING A/L WITH AN OPW (HASSTECH) VACUSMART DEVICE

The OPW (Hasstech) VacuSmart A/L test device is commonly used by service contractors and testing companies. The nozzle adapter for the VacuSmart was designed for use with a coaxial nozzle spout. The VST ENVIRO-LOC ORVR vacuum assist nozzle uses a solid spout, which is not compatible with a VacuSmart unit. You will need to perform the following steps in order to test the VST ENVIRO-LOC ORVR vacuum assist nozzle with a VacuSmart unit.

1. Purchase/obtain an A/L nozzle test adapter and a special VacuSmart test spout. These items are typically available from most petroleum equipment distributors.
2. Remove all fittings from the 3/4" NPT threaded opening in the A/L nozzle test adapter. **NOTE: This opening normally connects to the Roots meter.**
3. Install the VacuSmart test spout into the 3/4" NPT threaded opening on the A/L nozzle test adapter.
4. Install the A/L nozzle test adapter with the VacuSmart test spout onto the spout of the VST ENVIRO-LOC ORVR vacuum assist nozzle. Make sure the back of the adapter is making good contact with the face seal and is compressing the vapor collection sleeve. (see Figure 4.)

VST Installation Procedure for Stage II Vacuum Assist Nozzles

Part Number Series: VST-VR-NA(cc), VST-VR-NA(ccR)

cc = Scuff Guard Color Code and R = rebuilt

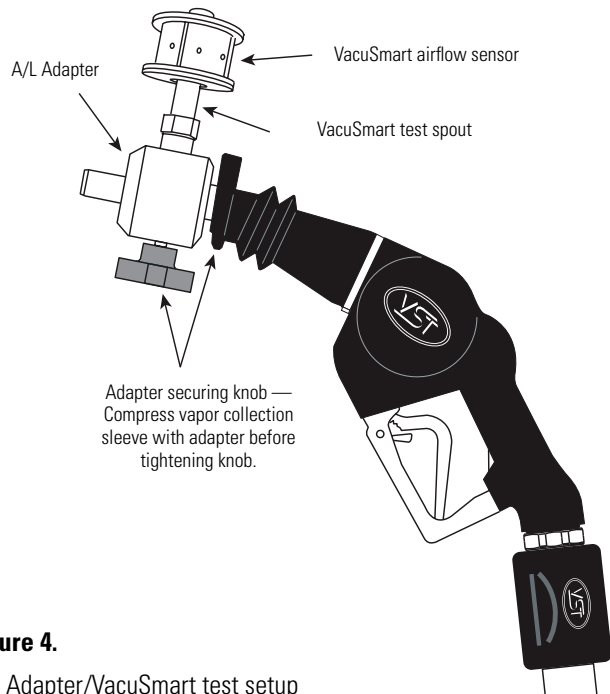

Figure 4.

A/L Adapter/VacuSmart test setup

5. Install the Airflow Sensor from the VacuSmart unit onto the special VacuSmart test spout. The holes in the test spout should be in between the elastomeric seals on the VacuSmart Airflow Sensor. (see Figure 4.)
6. Follow the VacuSmart instructions for testing the manufacturer's vacuum assist system with a 1.00 nominal A/L (mini-booted nozzle).

OTHER TESTS

Conduct other nozzle tests as required by local authorities.

MAINTENANCE

Inspect nozzles regularly for damaged component parts: vapor collection sleeve, face seal, spout, lever, hold-open clip, etc. Damaged components must be replaced. Vent hole at the end of the spout should be clear of debris. The nozzle will not operate if vent hole becomes clogged. Keep hose connections tight. Subject to customer abuse, nozzle should be replaced when damaged.

The nozzle is designed and constructed to give lasting service if properly handled and maintained. If for any reason it should need attention, contact your VST distributor for proper disposition.

NOTE: Due to abuse, misuse, changing gasoline formulas, variation in maintenance practices, environmental conditions and/or conditions beyond the manufacturer's control, dispensing equipment may need replacement before five (5) years. Inspections and proper maintenance procedures should be followed by the station manager to determine if replacement is required before five (5) years.

WARNING

Unauthorized rebuilding or modifying of nozzles voids ALL approvals and warranties.

VST products must be used in compliance with applicable federal, state and local laws and regulations.

If local regulatory codes prohibit use of the nozzle's hold-open clip, it must be removed prior to nozzle installation. Remove the nozzle to a safe work area. Place the nozzle on a flat surface. Locate the alloy rivet securing the hold-open clip and spring in the nozzle's handle. Use a drill with a 3/16" (5 mm) drill bit, drill out the rivet securing the hold-open clip, and discard the clip, spring, and all other rivet debris.



Vapor Systems Technologies, Inc.

650 Pleasant Valley Drive
Springboro, Ohio 45066 (USA)

Toll Free: 1-888-878-4673

Phone: 937-704-9333

Fax: 937-704-9443

www.vsthose.com