

# VST Installation Procedure for Phase II Coaxial EVR Balance Nozzle Repair Kits



**Vapor Systems Technologies, Inc.**

650 Pleasant Valley Drive  
Springboro, Ohio 45066 (USA)

Toll Free: 1-888-878-4673

Phone: 937-704-9333

Fax: 937-704-9443

www.vsthose.com

Part Number Series: VST-FEK-100 (Front End Kit includes VCK & NSA)  
VST-VCK-100 (Vapor Collection Kit: Boot Assembly Only)  
VST-NSA-100 (Nozzle Spout Assembly: Spout Assembly Only)

## TOOLS

Adjustable Wrench	Nozzle Band Clamp Pincers
Approved Fuel Container	Torque Wrench
Wide Mouth Funnel	Vaseline (or suitable lubricant)

## GENERAL INFORMATION

If hanging hardware components are involved in a drive-off or incur other customer abuse, each individual component must be functionally tested prior to customer dispensing activities.

## INSTALLATION PREPARATION

This procedure must be followed to insure leak-proof installation and operation of these nozzles.

1. Turn off and tag the power to the dispenser. Dispenser must be de-energized prior to service to avoid personal injury.
2. Barricade work area to block vehicle access to the dispenser.
3. Close the dispenser shear valve prior to removing hanging hardware (hoses, safety breakaways, and nozzles).
4. Visually inspect and assess the extent of the damage to all hanging hardware components. If there are no imperfections/damages, proceed to FUNCTIONAL TEST.
5. Drain liquid product from the hanging hardware set into an approved container prior to replacing any hanging hardware components.
6. Remove hanging hardware from the dispenser prior to making replacement component assembly connections. VST recommends connecting the whip hose to the dispenser as the last connection during the hanging hardware assembly.
7. To drain nozzle, engage nozzle interlock:
  - a. Push in face seal on nozzle boot assembly
  - b. Hold the backend of the nozzle over an approved container
  - c. Pull nozzle lever to fully drain the nozzle

## VAPOR COLLECTION KIT (VST-VCK-100) REMOVAL

(See Figure 1)

1. Remove large band clamp from the Vapor Collection assembly with nozzle band clamp pincers. (VST-BPT-100)
2. Pull the Vapor Collection assembly (boot) off of the clamping groove of nozzle body.
3. Pull Vapor Collection assembly off of the spout by slightly twisting to go over the spout latch ring.
4. Properly discard the removed components.

## VAPOR COLLECTION KIT (VCK) REPLACEMENT

1. Place the large band clamp on the collection sleeve. (See Figure 1)
2. Check proper orientation of the interlock rod. (See Figure 2)
3. Slide VCK over the spout.
4. Align and insert the interlock rod into the interlock port. (See Figure 2)
5. Align and center all alignment marks on top of the vapor collection kit and nozzle scuff. (See Figure 1)

6. Engage interlock a few times to check for correct alignment and functionality. (See Function Test 3)
7. Tighten collection band clamp until collection sleeve will not rotate. (See Figure 1)

## NOZZLE SPOUT ASSEMBLY (VST-NSA-100) REMOVAL

1. Remove Vapor Collection Assembly.
2. Loosen spout nut with smooth-jaw wrench. (See Figure 3)  
**NOTE** Do not use pipe wrench or locking-type pliers.
3. Once threads are completely disengaged, pull the spout straight out.

## NOZZLE SPOUT ASSEMBLY (NSA) REPLACEMENT (See Figure 3)

1. Fuel chamber should remain in the nozzle casting with the vacuum sensing tube hole oriented at the top.
2. If the fuel chamber is pulled out of the nozzle casting:
  - a. Check O-ring for damage.
  - b. Replace O-ring if damaged (check for cuts, nicks, etc.).
  - c. Lubricate O-ring prior to re-assembly.
3. Insert fuel chamber into nozzle casting:
  - a. Poppet stem with spring goes through poppet hole in the fuel chamber (center hole).
  - b. Push fuel chamber until it is flush with casting.
  - c. Vacuum sensing tube in the fuel chamber should be oriented at the top.

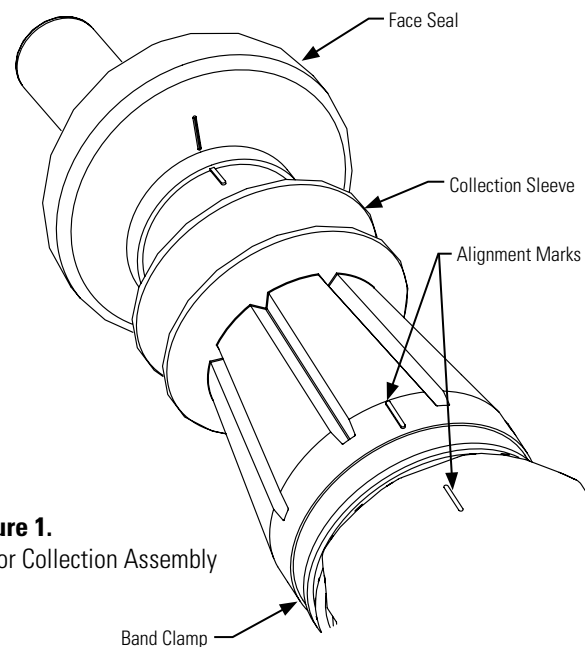

**Figure 1.**  
Vapor Collection Assembly

# VST Installation Procedure for Phase II Coaxial EVR Balance Nozzle Repair Kits

Part Number Series: VST-FEK-100 (Front End Kit includes VCK & NSA)  
 VST-VCK-100 (Vapor Collection Kit: Boot Assembly Only)  
 VST-NSA-100 (Nozzle Spout Assembly: Spout Assembly Only)

- Lightly lubricate **ALL** O-rings on the spout assembly.  
**NOTE** Do not block vacuum sensing-tube hole with lubricant.
- Align vacuum sensing tube with mating hole in the fuel chamber.
- Align the anti-rotation bump on the spout with the casting notch. Be careful not to damage the spout O-rings.
- Firmly insert spout assembly into the nozzle casting.
- Apply a dab of Loctite® 565 (or equivalent thread sealant) to the male thread of the nozzle casting. Be careful not to apply the Loctite® so that it would enter into the casting notch. (See Figure 3)
- Thread spout nut onto the nozzle casting and tighten firmly. Torque to 30 foot-pounds. Spout should be tight and not able to rotate. Do not over-tighten the spout nut.
- After tightening the spout nut, place the Vapor Collection Kit onto the spout. Examine the location of the interlock rod to make sure it does not interfere or ride against the spout nut. If there is interference, tighten the spout nut a few degrees to allow the interlock rod to move freely.
- Re-install the Vapor Collection Kit assembly per the Vapor Collection Kit Replacement instructions.

## FUNCTION TESTS

- Follow the VST Installation Procedure for each hanging hardware component. (Procedures: 9500-511, 9500-517, 9500-525)
- Purge air from the system by pumping one-tenth (1/10) to two-tenths (2/10) of a gallon of fuel into an approved container. Inspect the nozzle connection for liquid leaks and make proper adjustments at the hose connection if necessary.
- Check the nozzle shut-off action by dispensing fuel into an approved container at least three times to assure the proper automatic operation of the interlock rod. According to U/L requirement 842, the fuel flow-rate must be greater than 3 gpm for the automatic shut-off mechanism to operate.

To test, operate the nozzle and submerge the spout tip in fuel until the fuel level covers the vent hole. The main valve of the nozzle automatically shuts off when the liquid covers the vent hole at the end of the spout. The nozzle is not designed to operate on gravity flow. The hold-open latch will disengage automatically when liquid covers the vent hole in the spout. Verify that the fuel flow stops when the nozzle collection sleeve is decompressed (e.g. interlock rod is disengaged). To test that the fuel flow stops, dispense some fuel into an approved container. Slowly remove the nozzle from the container while dispensing fuel. Fuel flow should stop when the nozzle collection sleeve is fully decompressed.

- Measure the resistance between the dispenser outlet casting and the tip of the nozzle spout. Use an electronic multimeter set on the high range of the ohmmeter function. Resistance should not indicate more than 70,000 ohms per foot of the hose. Example: The measured resistance of a 12-foot hose must not exceed 840,000 ohms (840 kilohms).

**MAINTENANCE** Inspect nozzles daily for damaged components parts: vapor collection sleeve, face seal, interlock rod, spout, lever, lever lock, etc. Damaged components must be replaced. Vent hole at the end of the spout should be clear of debris. The nozzle will not operate properly if vent hole

becomes clogged. The nozzle will not function properly without the interlock rod properly engaged. Keep the hose connections tight.

Should there be a drive-off or incidence of customer abuse, follow the initial inspection instructions found in the VST Installation Procedure 9500-525. The nozzle should be replaced when damaged. The nozzle is designed and constructed to give lasting service if properly handled and maintained. If for any reason it should need attention, contact your VST distributor for proper disposition.

**NOTE** Due to abuse, misuse, changing gasoline formulas, variation in maintenance practices, environmental conditions, and/or conditions beyond the manufacturer's control, dispensing equipment may need replacement before five (5) years. Inspections and proper maintenance procedures should be followed by the station manager to determine if replacement is required before five (5) years.

**WARNING** Unauthorized rebuilding or modifying of nozzles voids ALL approvals and warranties. VST products must be used in compliance with applicable federal, state, and local laws and regulations. If local regulatory codes prohibit use of the nozzle's hold-open clip, it must be removed prior to nozzle installation. Remove the nozzle to a safe work area. Place the nozzle on a flat surface. Locate the alloy rivet securing the hold-open clip and spring in the nozzle's handle. Use a drill with a 3/16" (5mm) drill bit, drill out the rivet securing the hold-open clip, and discard the clip, spring, and all other rivet debris.

**Figure 2.**  
Interlock Assembly

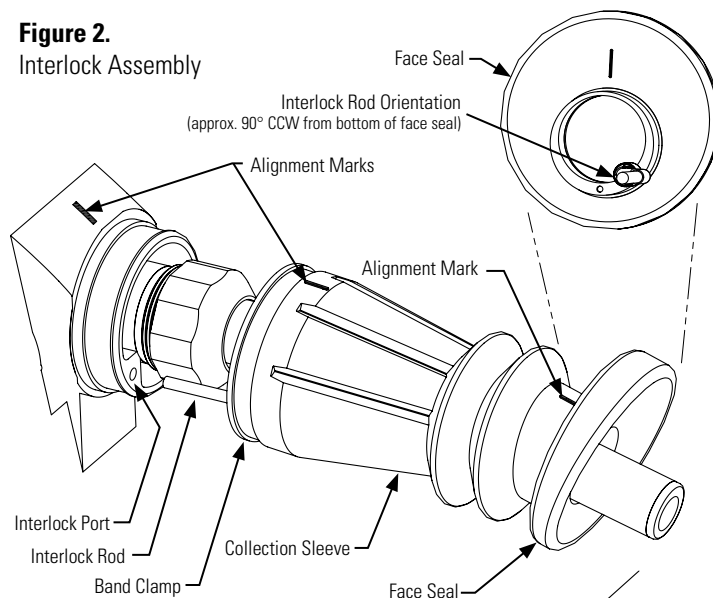

**FIGURE 3.**  
Spout Assembly

